

SILICON MICROWAVE POWER TRANSISTOR

PRODUCT DATA SHEET

FEATURES:

- High Output Power
6W @ 1.0 GHz
- High Gain Bandwidth Product
 $f_t = 6.0 \text{ GHz @ } I_C = 1200 \text{ mA}$
- High Gain
 $G_{PE} = 10.0 \text{ dB @ } 1.0 \text{ GHz}$

DESCRIPTION AND APPLICATIONS:

Bipolarics' B20V1480 is a high performance, low cost silicon bipolar transistor intended for linear power applications at frequencies of 0.5 to 2.6 GHz. Uniformity and reliability are assured by the use of advanced process techniques: ion implanted junctions, ion implanted ballast resistors and gold metallization. When the B20V1480 is bonded common emitter, linear output power of 4 Watt can be achieved.

Absolute Maximum Ratings:

SYMBOL	PARAMETERS	RATING	UNITS
V_{CBO}	Collector-Base Voltage	40	V
V_{CEO}	Collector-Emitter Voltage	20	V
V_{EBO}	Emitter-Base Voltage	3.0	V
I_C	Collector Current (instantaneous)	1200	mA
T_J	Junction Temperature	200	°C
T_{STG}	Storage Temperature	-65 to +150	°C

PERFORMANCE DATA:

- Electrical Characteristics ($T_A = 25^\circ\text{C}$)

SYMBOL	PARAMETERS & CONDITIONS <small>$V_{CE} = 15\text{V}, I_C = 1200 \text{ mA}, \text{Class A}, \text{ unless stated}$</small>	UNIT	MIN.	TYP.	MAX.
P_{1dB}	Power output at 1 dB compression: $f = 1.0 \text{ GHz}$	W		6.0	
G_{1dB}	Gain at 1dB compression: $f = 1.0 \text{ GHz}$	dB		10.0	
η	Collector Efficiency Class A	%		30	
C_{CB}	Collector Base Capacitance: $f = 1 \text{ MHz}, I_E = 0$	pF	2.6	4.0	
h_{FE}	Forward Current Transfer Ratio: $V_{CE} = 8\text{V}, I_C = 400 \text{ mA}$		20	60	100
P_T	Total Power Dissipation	W		18	

SILICON MICROWAVE POWER TRANSISTOR

20 0.200" Pill Package

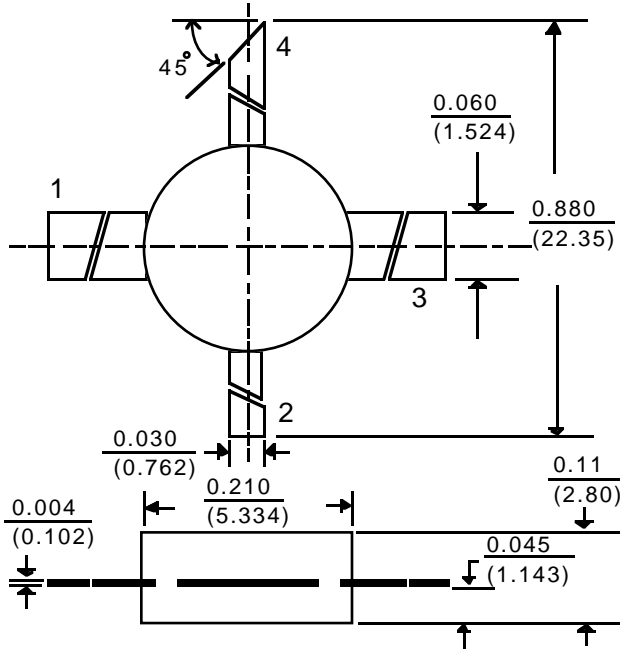

28 0.280" Pill Package

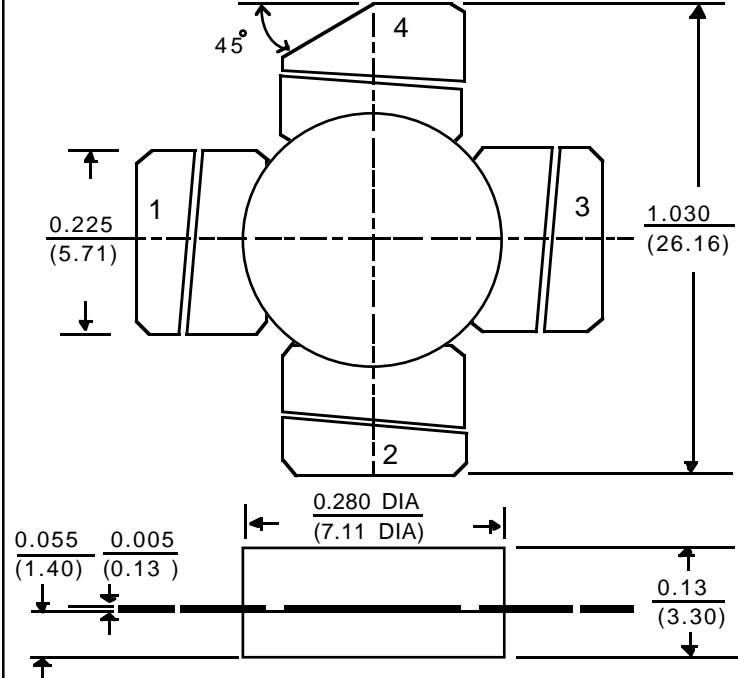

50 Ceramic 4 Lead PAK Surface Mount

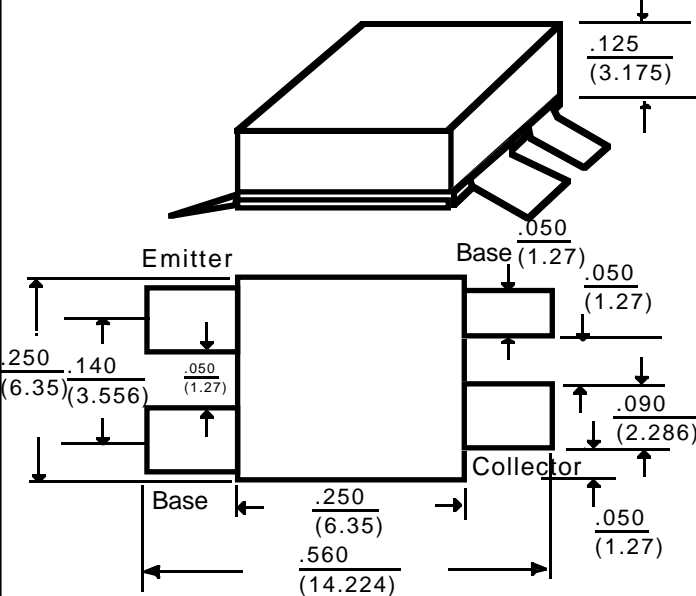

08 Ceramic SO8 Package

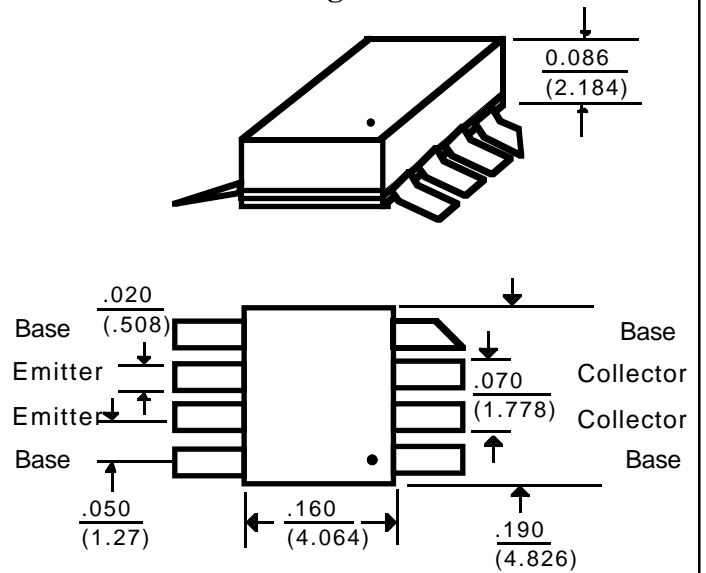

NOTES: (unless otherwise specified)

1. Dimensions are $\frac{\text{in}}{\text{(mm)}}$
2. Tolerances:
 in .xxx = $\pm .005$
 mm .xx = $\pm .13$
3. All dimensions nominal; subject to change without notice

Drawings are not to scale.

LEAD	1	2	3	4
20 & 28 Package	Base	Emitter	Base	Collector